

OFFICINE MECCANICHE



52031 ANGHIARI (AREZZO) - ITALY - LOC. S. LORENZO N. 40 TEL. (0575) 789055 - FAX (0575) 788245
E-mail: biagioli@aratribiagioli.it - Internet: www.aratribiagioli.it



**ARATRI
PORTATI
A
SPOSTAMENTO
TRASVERSALE
PER
TRATTORI
A RUOTE**

- Le caratteristiche ed i dati tecnici si intendono forniti a semplice titolo indicativo e non impegnativo.
- All technical data and features given for information only and are not binding.
- Les caractéristiques et les indications techniques sont fournies à titre indicatif e sans engagement.
- Las características técnicas son solamente indicativas y sin empeño.



OFFICINE MECCANICHE
ARATRI BIAGIOLI s.a.s.

Traversable mounted ploughs for wheeled tractors.

Charrues portées avec déplacement transversal pour tracteur à roues.

Arados colgados con excursion transversal para tractores de ruedas.

Trattore Tractor Tracteur Tractor HP	Modello Model Modèle Modelo	Lavoro - Working Travail - Trabajo		Peso Weight Poids Peso Kg
		Largh. Width Largeur Amplitud cm	Prof. Depth Profon. Profun. cm	
30 - 35	AR - 30T			65
	ARC - 30T			75
	MS - 02C	34	27	80
	BS - 05	55	18	110
35 - 40	TS - 06	82	12	125
	AR - 30L			90
	ARC - 30L			105
	MS - 01L	37	30	95
40 - 45	BS - 04	60	20	140
	TS - 05	82	15	145
	AR - 30			90
	ARC - 30			105
45 - 50	MS - 01R	37	34	110
	BS - 03A	65	22	160
	TS - 04	90	18	210
	AR - 40			100
50 - 58	ARC - 40			115
	MS - 0	40	35	125
	BS - 03B	65	25	165
	TS - 04	90	18	210
58 - 68	AR - 45			110
	ARC - 45			125
	MS - 0R	40	37	135
	BS - 02	68	28	220
68 - 78	TS - 04	90	20	220
	AR - 50			145
	ARC - 50			165
	MS - 1	44	42	170
78 - 88	BS - 02C	69	28	240
	TS - 03B	96	20	290
	AR - 60			165
	ARC - 60			185
85 - 95	MS - 2	45	45	190
	BS - 01L	73	30	280
	TS - 03B	96	25	290
	AR - 70			215
95 - 105	ARC - 70			240
	MS - 3	47	47	220
	BS - 01R	74	34	315
	TS - 02	102	28	320
105 - 130	ARC - 80			250
	MS - 4	50	50	290
	BS - 0	81	35	360
	TS - 02C	102	28	370
130 - 160	ARC - 80			250
	MS - 5	50	55	300
	BS - 0R	81	37	370
	TS - 01L	110	30	460
160 - 190	ARC - 100			305
	MS - 6	55	58	345
	BS - 1	86	42	520
	TS - 01R	110	34	540
160 - 190	ARC - 120			385
	MS - 7	60	62	455
	BS - 2	90	45	565
	TS - 0R	122	37	610
160 - 190	ARC - 150			420
	MS - 8	60	65	485
	BS - 3	96	48	640
	TS - 1	130	42	745

PORTATTREZZI NORMALE A SPOSTAMENTO BILATERALE
Normal tool-carrier with bilateral traversing
Porte-outils normal avec déplacement bilatéral
Porta-aperos normal con excursion bilateral } Mod. AR

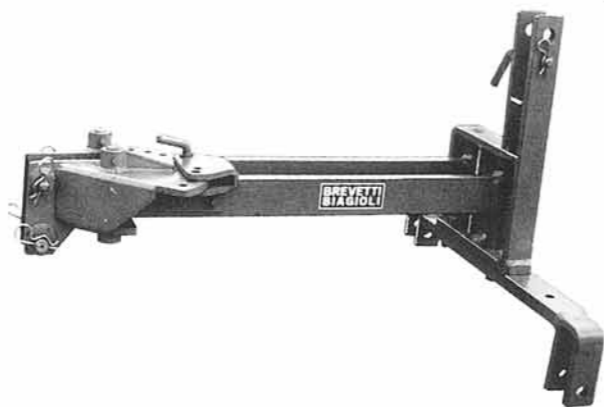

PORTATTREZZI STERZANTE A SPOSTAMENTO BILATERALE
Steering tool-carrier with bilateral traversing
Porte-outils articulé avec déplacement bilatéral
Porta-aperos articulado con excursion bilateral } Mod. ARC



CORPO MONOVOMERE A SCALPELLO
Single furrow chisel body
Corp monosoc avec ciseau
Cuerpo monosurco con cincel } Mod. MS

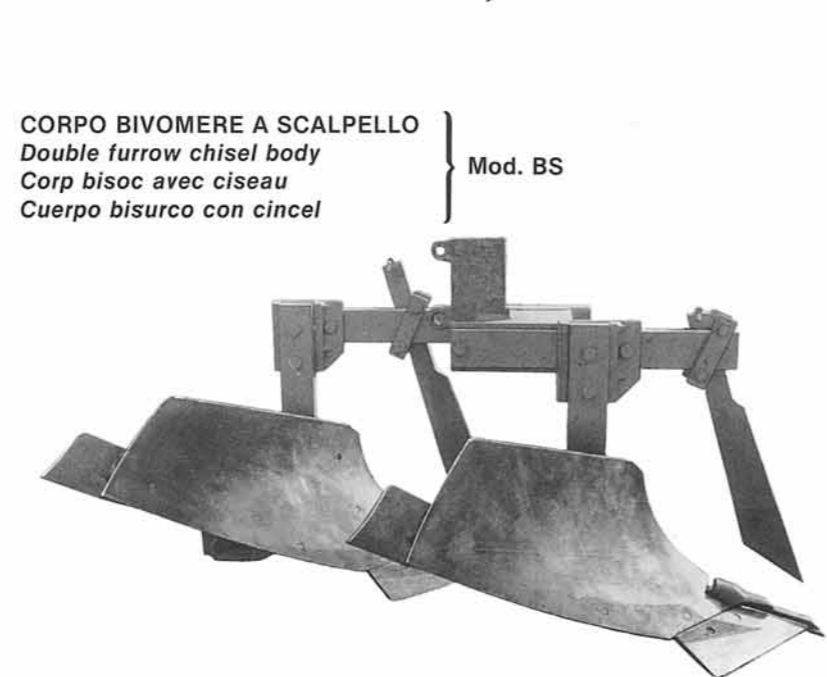

CORPO BIVOMERE A SCALPELLO
Double furrow chisel body
Corp bisoc avec ciseau
Cuerpo bisurco con cincel } Mod. BS

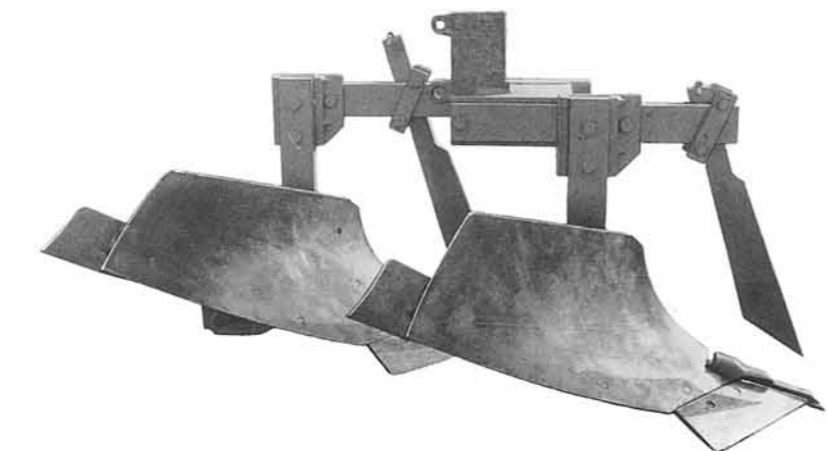

CARATTERISTICHE TECNICHE

- Attacco a tre punti unificato
- Portattrezzi BREVETTATO con ampio e rapido spostamento bilaterale (Fig. 1) per regolazione larghezza di lavoro e rifiniture a filo esterno ruota sinistra (a richiesta con comando idraulico - Fig. 2)
- Collegamento sterzante elastico (Fig. 3) al trattore per migliore manovrabilità a fine solco
- Corpi disponibili con vomeri normali o con punta a scalpello
- Possibilità applicazione al portattrezzi di elemento ripuntatore e lama livellatrice
- Grande robustezza costruttiva con parti sollecitate in acciaio trattato
- A richiesta: Avanzomeri normali o a disco

TECHNICAL FEATURES

- Standard three point hitch
- PATENTED tool-carrier with large and quick traversing (Pict. 1) for work width adjustment and edge ploughing up to external left wheel-line (with optional hydraulic control - Pict. 2)
- Elastic steering linkage (Pict. 3) to obtain the best conditions of manoeuvre at the end of furrow
- Standard share or chisel bodies available
- A ripper or a grader can also be placed on the tool-carrier
- Sturdy structure with heavy duty parts made in treated steel
- Optionals: Standard skimmers or disk skimmers

CARACTERISTIQUES TECHNIQUES

- Attelage à trois points standardisé
- Porte-outils BREVETE avec grand et rapide déplacement transversal bilatéral (Des. 1) pour réglage largeur de travail et pour travail jusqu'au côté extérieur de la roue gauche du tracteur (sur demande avec commande hydraulique - Des. 2)
- Jonction élastique articulée (Des. 3) au tracteur pour mieux manoeuvrer à la fin du sillon
- Corps avec soc normal ou à ciseau
- Sur le port-outils sont interchangeable lame niveleuse et sous-soleuse
- Construction robuste avec pièces sujetes à effort batiées en acier traité
- Sur demande: Rasette standard ou à disque

CARACTERISTICOS DE CONSTRUCCION

- Enganche de tres puntos unificado
- Porta-aperos PATENTADO con grande y rapida excursion transversal bilatéral (Fig. 1) para la regulación de la amplitud de trabajo y para trabajo hasta lado exterior de la rueda izquierda del tractor (a pedido con movimiento hidráulico - Fig. 2)
- Conexión articulada elástica con el tractor (Fig. 3) para maniobrar mejor a la fin del surco
- Cuerpos con reja normal o con cincel de refuerzo
- Porta-aperos con cuchilla niveladora y subsolador de intercambio
- Construcción robusta con las partes más expuestas a esfuerzo de acero especial
- A pedido: Reja pequeña anterior o a disco para enterrar el cespèd

CORPO TRIVOMERE A SCALPELLO
Three furrow chisel body
Corp trisoc avec ciseau
Cuerpo trisurco con cincel } Mod. TS

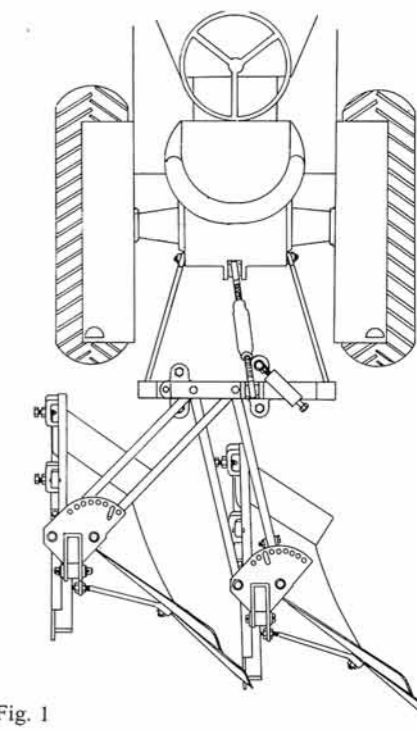
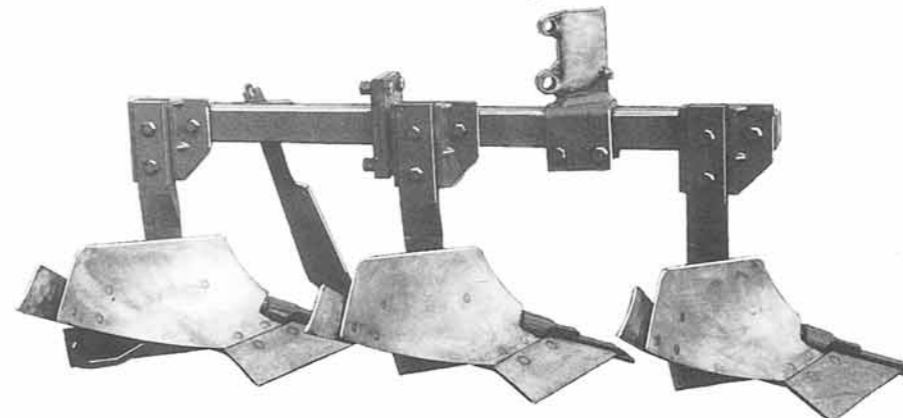

Fig. 1

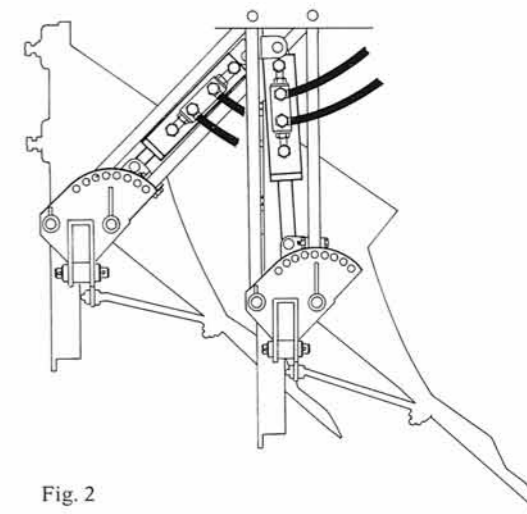

Fig. 2

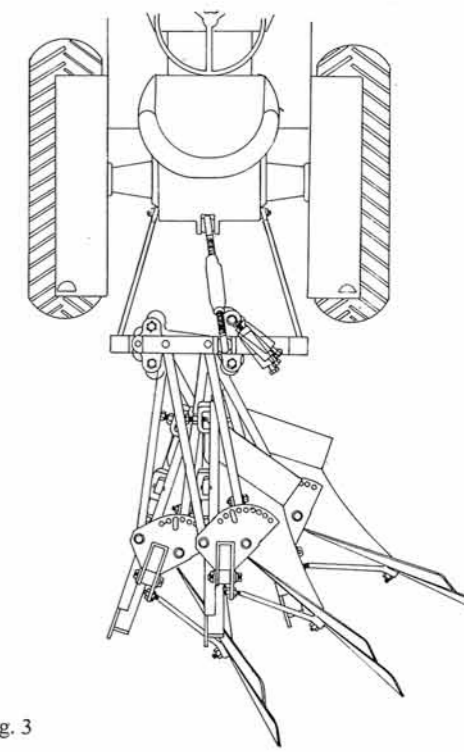

Fig. 3